

TENTATIVE SUBDIVISION MAP AMORUSO RANCH PHASE 1 - SUBPHASE A2

CITY OF ROSEVILLE, CALIFORNIA
NOVEMBER 1, 2022

PROJECT NOTES

RECORD OWNER BROOKFIELD SACRAMENTO HOLDINGS, LLC 2271 LAVA RIDGE CT, SUITE 220 ROSEVILLE, CA 95661 CONTACT: JOHN NORMAN PHONE: (916) 783-1177	ASSESSOR'S PARCEL NUMBERS 017-470-011 THROUGH ...-0013, -035 & -036 017-480-005, -014 THROUGH ...-016	EXISTING USE VACANT	SCHOOL DISTRICT ROSEVILLE CITY SCHOOL DISTRICT ROSEVILLE JOINT UNION HIGH SCHOOL DISTRICT
APPLICANT BROOKFIELD RESIDENTIAL 2271 LAVA RIDGE CT, SUITE 220 ROSEVILLE, CA 95661 CONTACT: JOHN NORMAN PHONE: (916) 783-1177	AREA 34.5 ± ACRES	PROPOSED USE FUTURE PLANNED DEVELOPMENT	SEWER CITY OF ROSEVILLE
ENGINEER/PLANNER WOOD RODGERS INC. 3301 C STREET, BLDG. 100B SACRAMENTO, CA 95816 CONTACT: PAUL KLEIN, PE #48367 VANCE JONES PHONE: (916) 341-7760	NUMBER OF PARCELS 156 SINGLE FAMILY RESIDENTIAL PARCELS 2 PARK PARCELS 1 OPEN SPACE PARCELS 3 WATER QUALITY PARCELS 162 TOTAL PARCELS	EXISTING ZONING RS, FR, & OS	STORM DRAIN CITY OF ROSEVILLE
NOTE: 1) SUBDIVIDER(S) RESERVES THE RIGHT TO FILE MULTIPLE FINAL MAPS PURSUANT TO SECTION 66456.1 OF THE SUBDIVISION MAP ACT. 2) A 10' P.U.E. SHALL BE LOCATED ADJACENT TO ALL PUBLIC STREETS UNLESS OTHERWISE SHOWN ON THIS EXHIBIT. 3) MASTER PARCEL NUMBERING IS FOR IDENTIFICATION PURPOSES ONLY AND DOES NOT INDICATE PHASING ORDER OF DEVELOPMENT. 4) ALL EXISTING STRUCTURES TO BE REMOVED AND ALL EXISTING WELLS TO BE ABANDONED. 5) EXISTING TOPOGRAPHY PROVIDED BY OTHERS. 6) THIS IS AN APPLICATION FOR A DEVELOPMENT PERMIT. 7) THIS EXHIBIT IS FOR TENTATIVE MAP PURPOSES ONLY. ALL SITE CHARACTERISTICS ARE TO BE VERIFIED PRIOR TO FINAL MAP. 8) PURSUANT TO SECTION 66499.20.2 OF THE SUBDIVISION MAP ACT, THE LAND SHOWN HEREON IS HEREBY TO BE MERGED AND RE-SUBDIVIDED. 9) MASTER PARCEL LINES SHOWN HEREON ARE SUBJECT TO CHANGE AS ACCESS, PUBLIC UTILITIES AND/OR PHASING REQUIREMENTS DICTATE. 10) FUTURE PUBLIC LANDS, INCLUDING OPEN SPACE, DRAINAGE CHANNELS AND PARKS TO BE DEDICATED TO THE CITY AS AN IRREVOCABLE OFFER OF DEDICATION (IOD). 11) OFF-SITE DRAINAGE IMPROVEMENTS TO BE CONSTRUCTED PER AMORUSO RANCH SPECIFIC PLAN DRAINAGE STUDY AND DEVELOPMENT AGREEMENT.	PROPOSED ZONING SEE LAND USE SUMMARY BELOW	WATER CITY OF ROSEVILLE	ELECTRICITY CITY OF ROSEVILLE
		PARKS AND OPEN SPACE CITY OF ROSEVILLE	GAS PG&E
		FIRE PROTECTION CITY OF ROSEVILLE	

LEGEND

PROJECT BOUNDARY	---
VILLAGE LOT LINE	---
RIGHT-OF-WAY	---
STREET CENTERLINE	---
PROPOSED LOTS	---
PUE (TYP)	---
VILLAGE BOUNDARY	---
TOP BACK OF CURB	---
SIDEWALK	---
LIP OF CURB	---
SEWER MAIN	---
SEWER MANHOLE	---
DRAINAGE MAIN	---
DRAINAGE MANHOLE	---
DRAIN INLET	---
WATER MAIN	---
GATE VALVE	---
FIRE HYDRANT	---

SHEET INDEX

1	COVER SHEET-NOTES - SECTIONS	1"=200'
2	TENTATIVE SUBDIVISION MAP	1"=40'
3	TENTATIVE SUBDIVISION MAP	1"=40'

LOCATION MAP

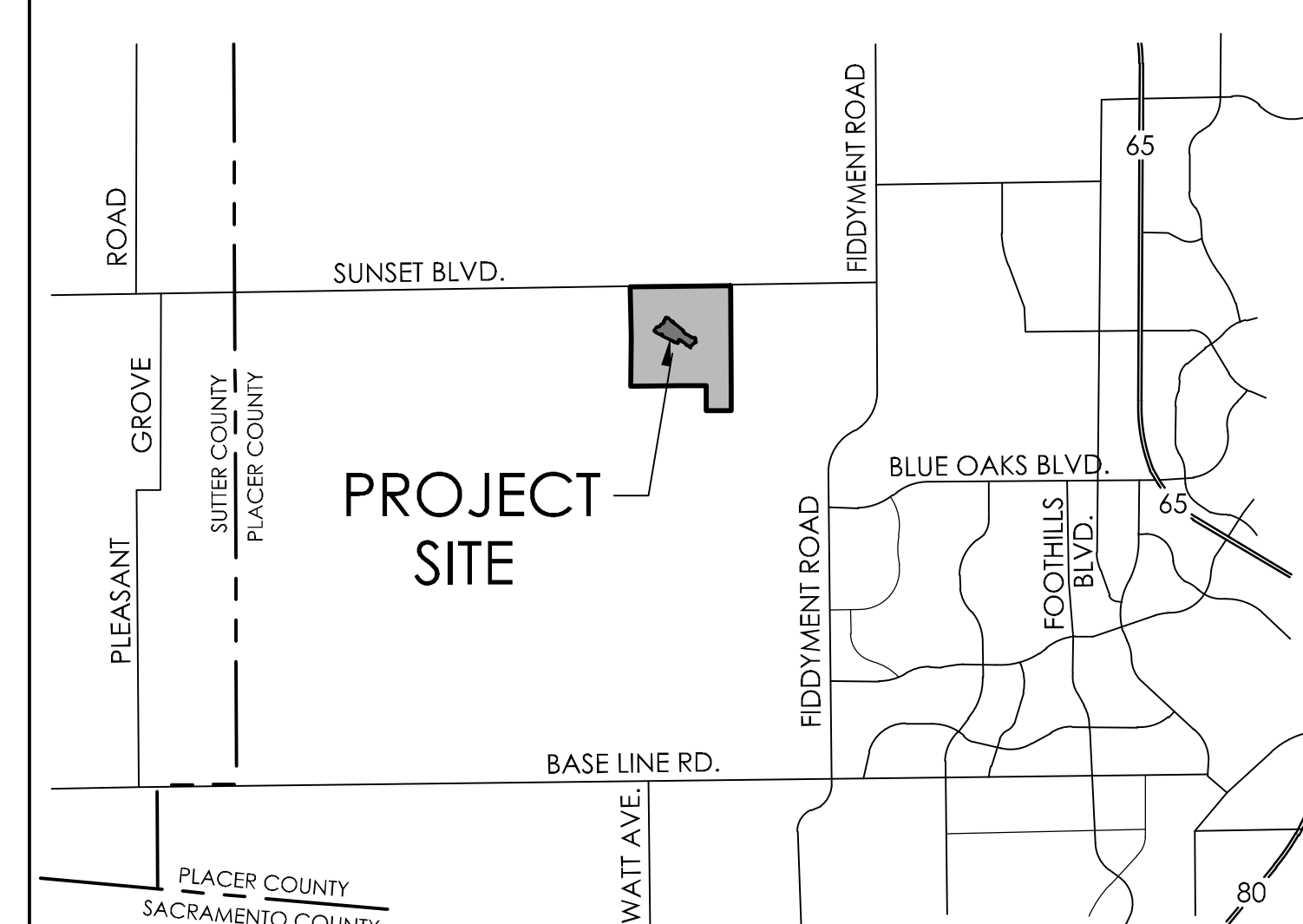

SHEET INDEX DIAGRAM

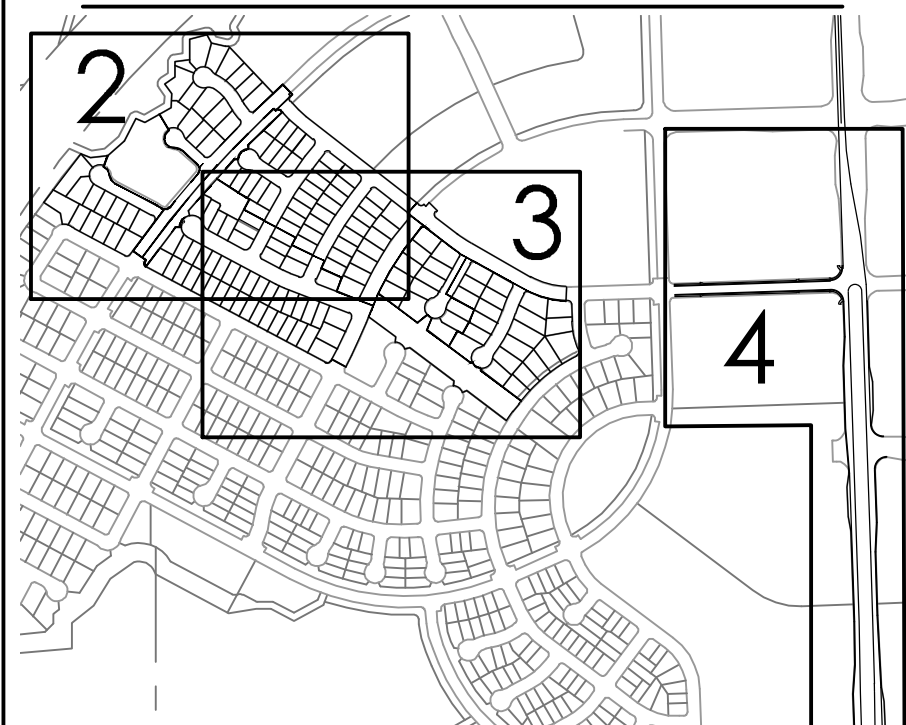

STREET SECTIONS

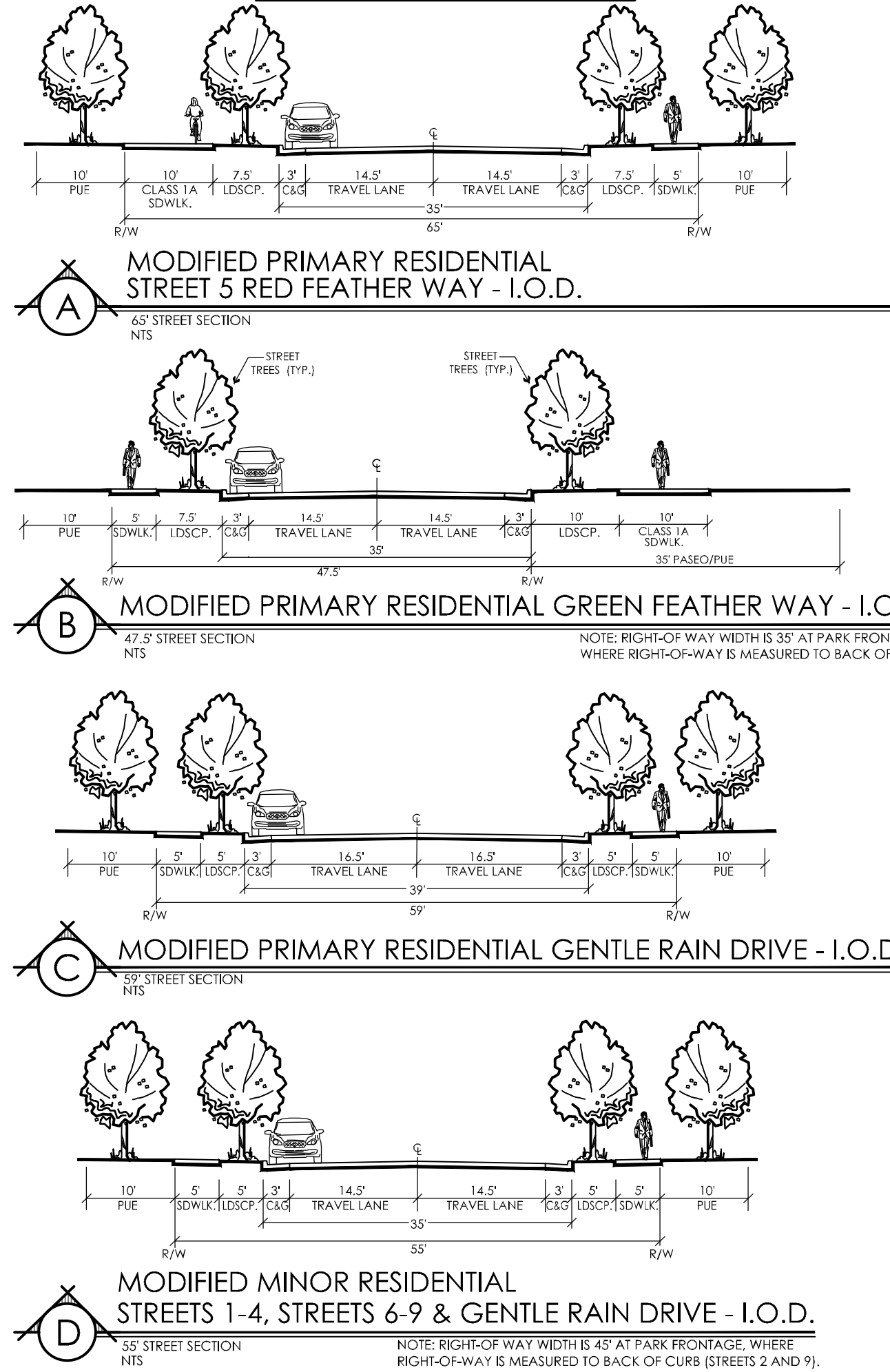

BOUNDARY GRADING SECTIONS

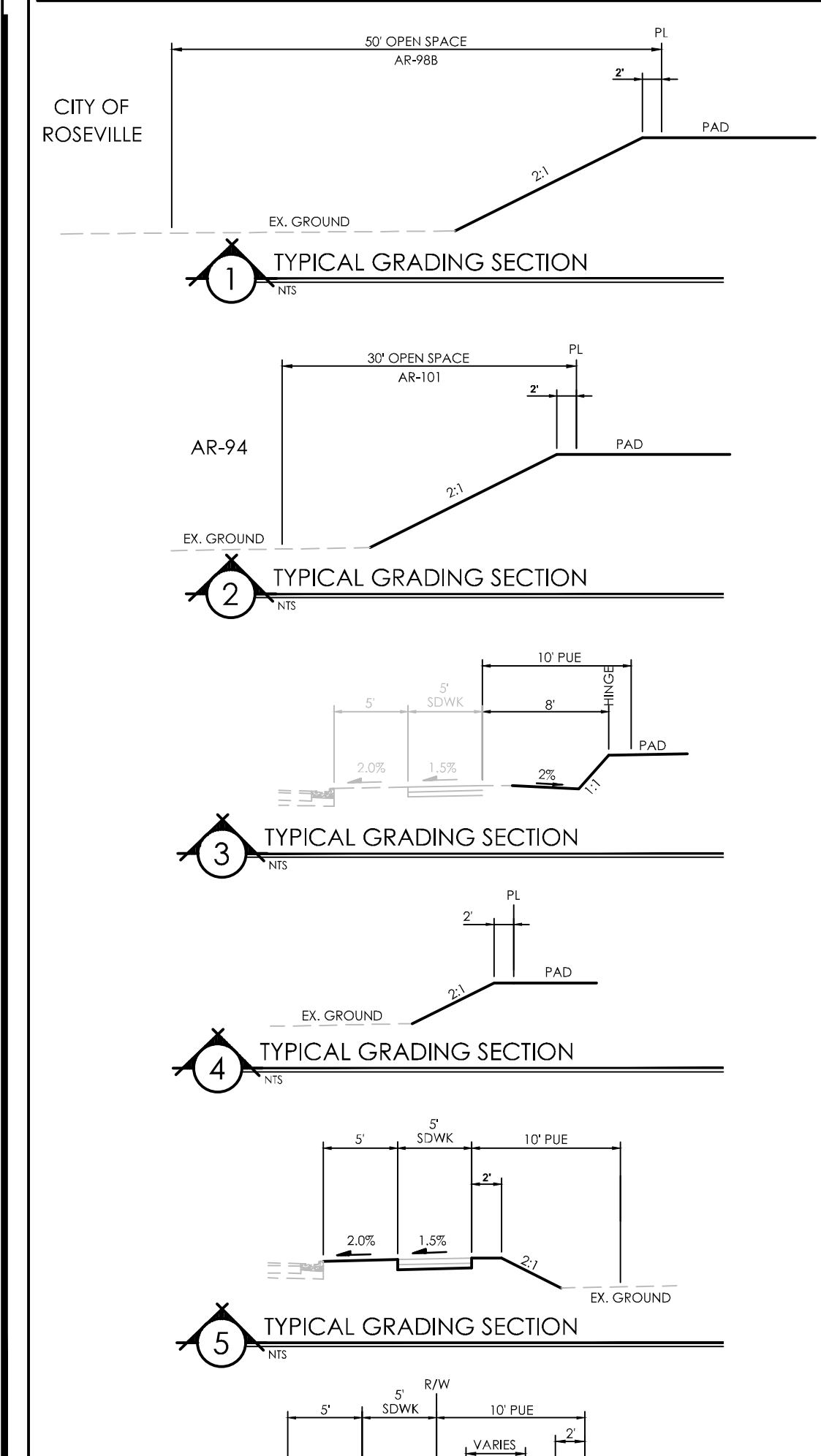

UTILITY SECTIONS

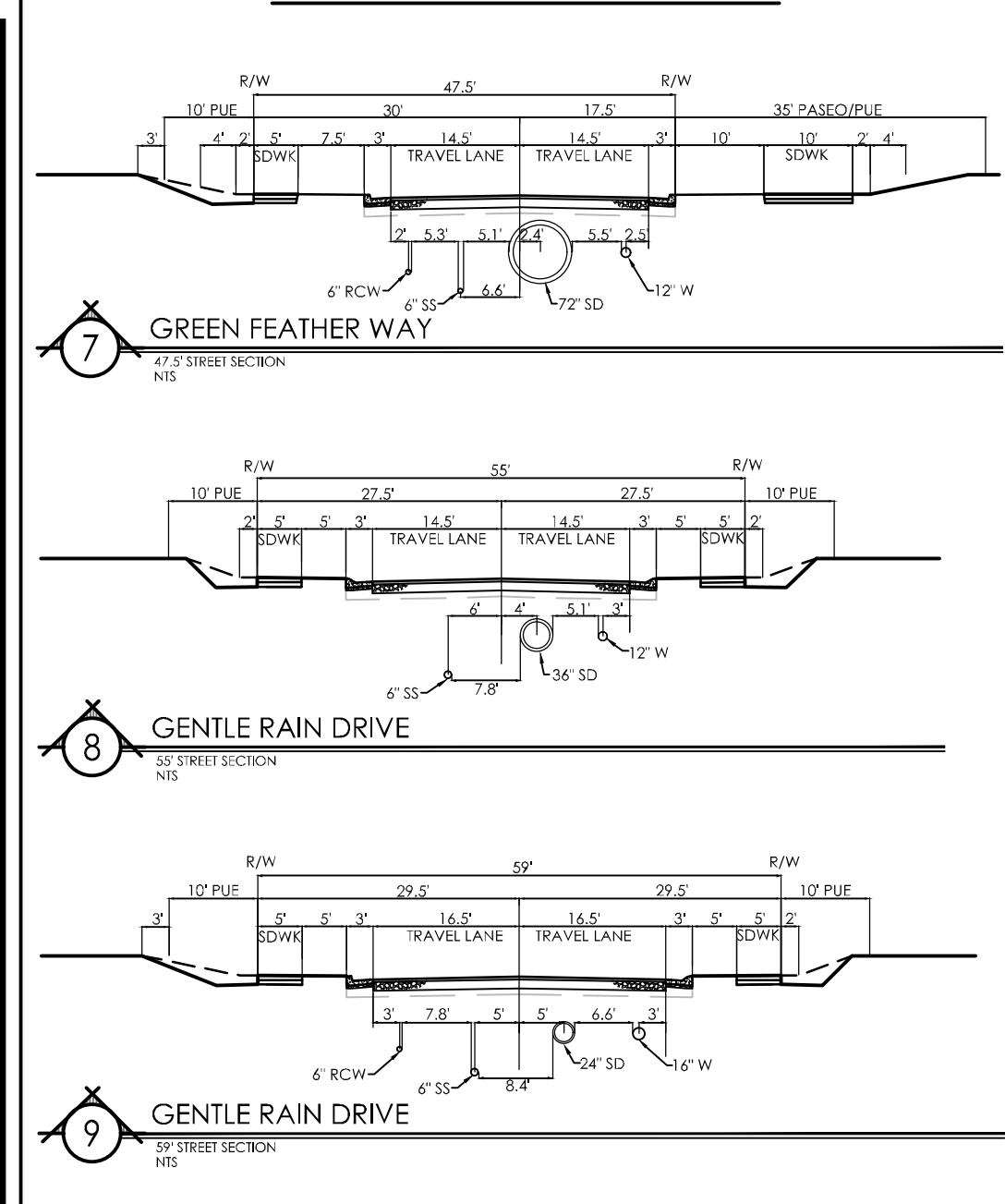

EARTHWORK SUMMARY

ESTIMATED RAW EXCAVATION:	42,900	CUBIC YARDS
ESTIMATED RAW FILL:	66,100	CUBIC YARDS
ESTIMATED IMPORT:	18,200	CUBIC YARDS

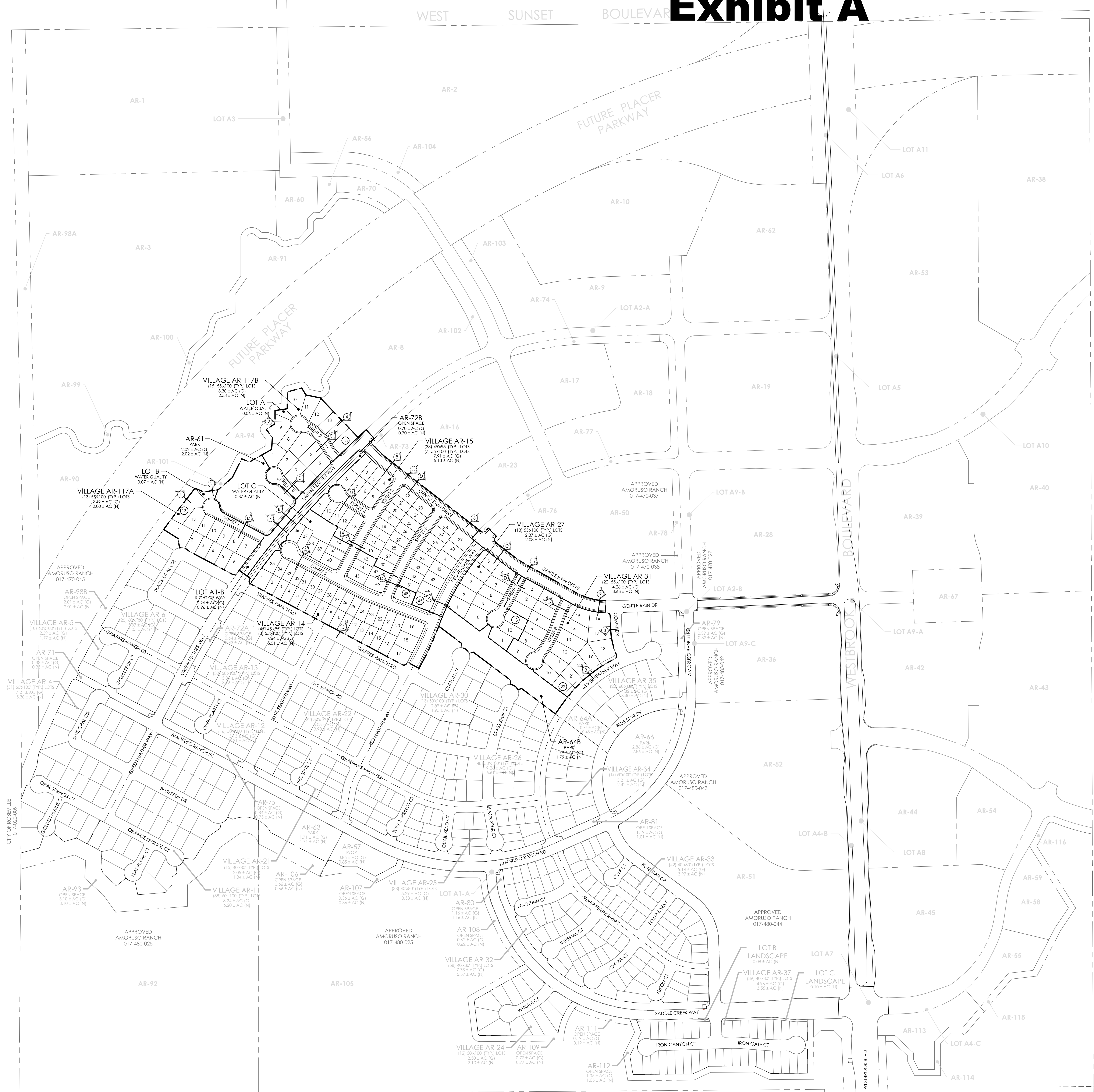
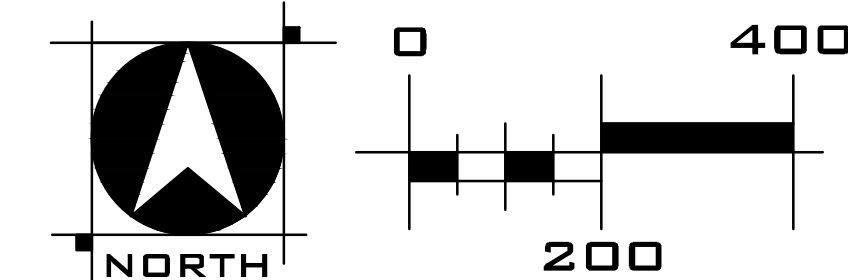

LAND USE SUMMARY

FINAL MAP	LOT NO.	GENERAL PLAN DESIGNATION	SPECIFIC PLAN DESIGNATION	ZONING	LAND USE DESCRIPTION	MINIMUM LOT DIM.	DWELLING UNITS	GROSS ACRES	NET ACRES	DENSITY	
16	AR-117A	LDR	LDR	RS	LOW DENSITY RESIDENTIAL	55x100	13	2.49	2.00	5.2	
18	AR-117B	LDR	LDR	RS	LOW DENSITY RESIDENTIAL	55x100	15	3.30	2.58	4.5	
41	AR-15	LDR	LDR	RS	LOW DENSITY RESIDENTIAL	45x95	38	7.91	5.13	5.7	
42	AR-14	LDR	LDR	RS	LOW DENSITY RESIDENTIAL	45x95	45	7.44	5.31	6.3	
52	AR-27	LDR	LDR	RS	LOW DENSITY RESIDENTIAL	55x100	13	3.37	2.08	5.5	
53	AR-31	LDR	LDR	RS	LOW DENSITY RESIDENTIAL	55x100	22	4.26	3.43	5.2	
SUBTOTAL							156	27.97	20.73		
17	AR-61	P/R	P/R	FR	PARKS & RECREATION	-	-	3.02	3.02	-	
51	AR-64B	P/R	P/R	FR	PARKS & RECREATION	-	-	1.79	1.79	-	
101	AR-72B	OS	OS	OS	OS/PHASED	-	-	0.70	0.70	-	
SUBTOTAL								4.81	4.81		
MAJOR RIGHT-OF-WAY											
GENTLE RAIN DRIVE						RIGHT-OF-WAY	-	1.05	1.05	-	
GREEN FEATHER WAY						RIGHT-OF-WAY	-	0.95	0.95	-	
SUBTOTAL								3.00	3.00		
MINOR RIGHT-OF-WAY											
A	A	LDR	LDR	RS	WATER QUALITY LOT	-	-	-	0.06	-	
B	B	LDR	LDR	RS	WATER QUALITY LOT	-	-	-	0.07	-	
C	C	LDR	LDR	RS	WATER QUALITY LOT	-	-	-	0.37	-	
SUBTOTAL									0.50	0.50	
TOTAL									156	34.48	34.48
									DV	AC	AC

NOTE: NET CREAGE EXCLUDES MINOR RIGHT-OF-WAYS AND LANDSCAPE LOTS.

CITY APPROVAL STAMP

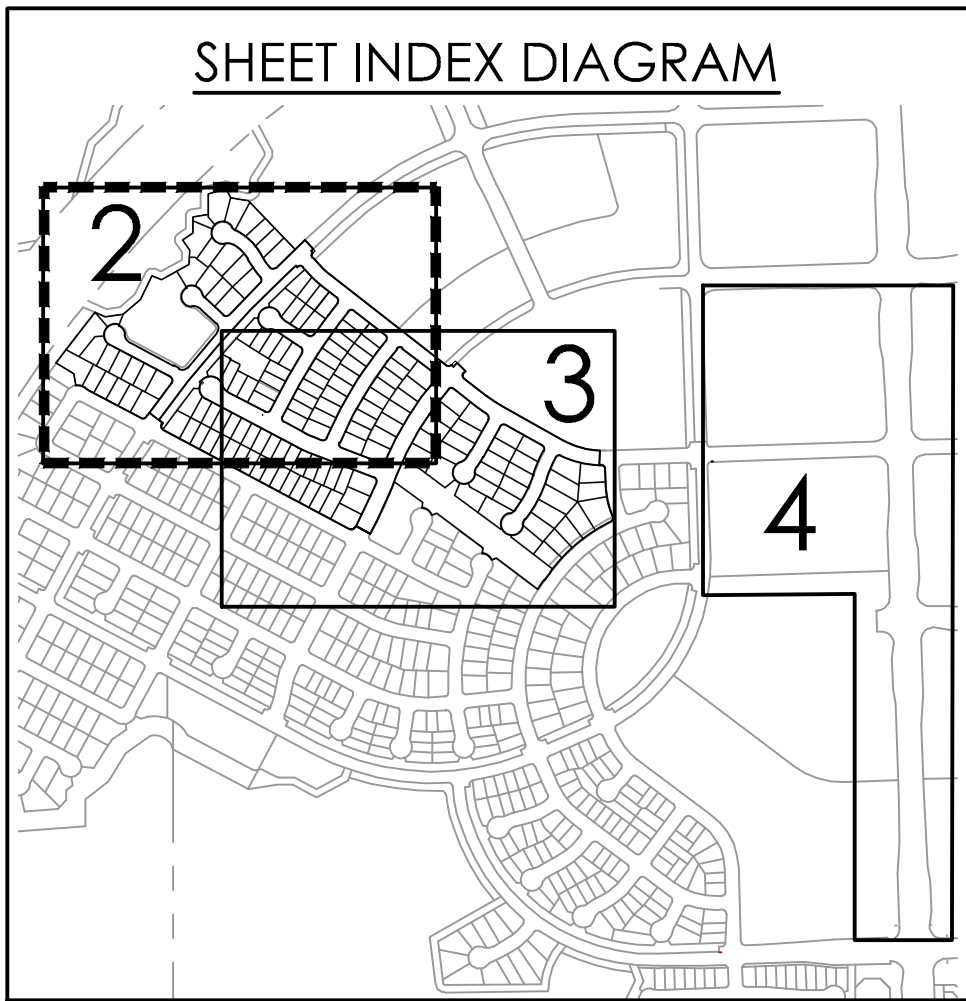

TENTATIVE SUBDIVISION MAP AMORUSO RANCH PHASE 1 - SUBPHASE A2

CITY OF ROSEVILLE, CALIFORNIA
NOVEMBER 1, 2022

LEGEND			
PROJECT BOUNDARY	--- --	SEWER MAIN	—●—
VILLAGE LOT LINE	— · — · —	SEWER MANHOLE	●
RIGHT-OF-WAY	— · — · —	DRAINAGE MAIN	—●—
STREET CENTERLINE	— · — · —	DRAINAGE MANHOLE	●
PROPOSED LOTS	— · — · —	DRAIN INLET	—●—
		WATER MAIN	—●—
		TOP BACK OF CURB	— · — · —
		SIDEWALK	— · — · —
		LIP OF CURB	— · — · —
		GATE VALVE	—●—
		FIRE HYDRANT	●

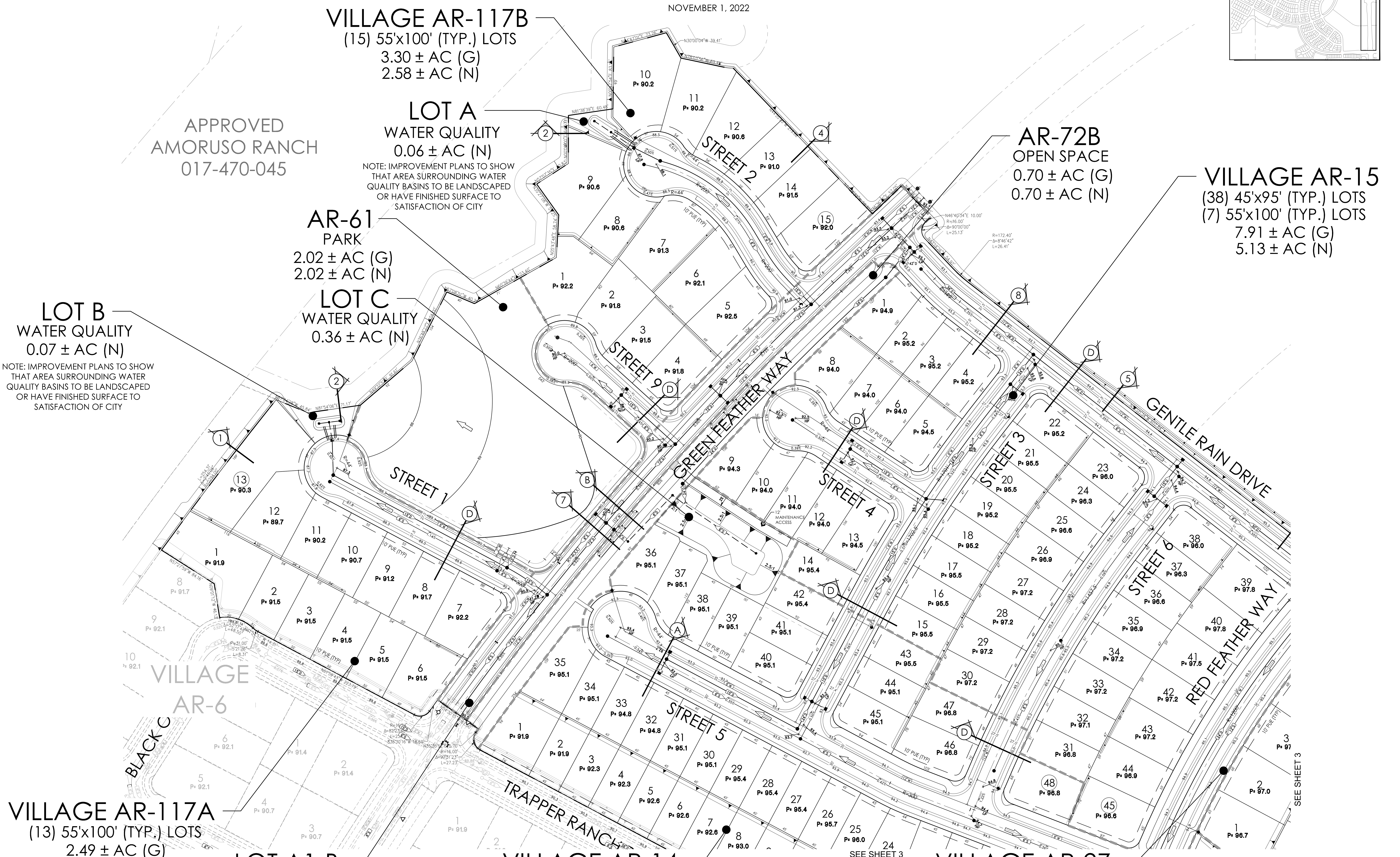

VILLAGE AR-117B
(15) 55'x100' (TYP.) LOTS
3.30 ± AC (G)
2.58 ± AC (N)

LOT A
WATER QUALITY
0.06 ± AC (N)

NOTE: IMPROVEMENT PLANS TO SHOW THAT AREA SURROUNDING WATER QUALITY BASINS TO BE LANDSCAPED OR HAVE FINISHED SURFACE TO SATISFACTION OF CITY

APPROVED AMORUSO RANCH
017-470-045

AR-72B
OPEN SPACE
0.70 ± AC (G)
0.70 ± AC (N)

VILLAGE AR-15
(38) 45'x95' (TYP.) LOTS
(7) 55'x100' (TYP.) LOTS
7.91 ± AC (G)
5.13 ± AC (N)

LOT B
WATER QUALITY
0.07 ± AC (N)

NOTE: IMPROVEMENT PLANS TO SHOW THAT AREA SURROUNDING WATER QUALITY BASINS TO BE LANDSCAPED OR HAVE FINISHED SURFACE TO SATISFACTION OF CITY

AR-61
PARK
2.02 ± AC (G)
2.02 ± AC (N)

LOT C
WATER QUALITY
0.36 ± AC (N)

VILLAGE AR-117A
(13) 55'x100' (TYP.) LOTS
2.49 ± AC (G)
2.00 ± AC (N)

LOT A1-B
RIGHT-OF-WAY
0.95 ± AC (G)
0.95 ± AC (N)

VILLAGE AR-14
(45) 45'x95' (TYP.) LOTS
(3) 55'x100' (TYP.) LOTS
7.64 ± AC (G)
5.13 ± AC (N)

VILLAGE AR-27
(13) 55'x100' (TYP.) LOTS
2.37 ± AC (G)
2.08 ± AC (N)

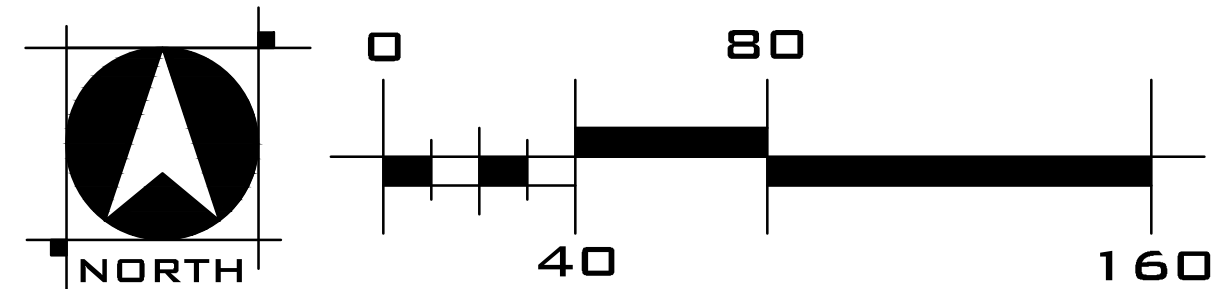

WOOD RODGERS
DEVELOPING INNOVATIVE DESIGN SOLUTIONS
3301 C St. Bldg. 100-B
Sacramento, CA 95816
Tel 916.341.7760
Fax 916.341.7767

CITY APPROVAL STAMP

SHEET 2 OF 4

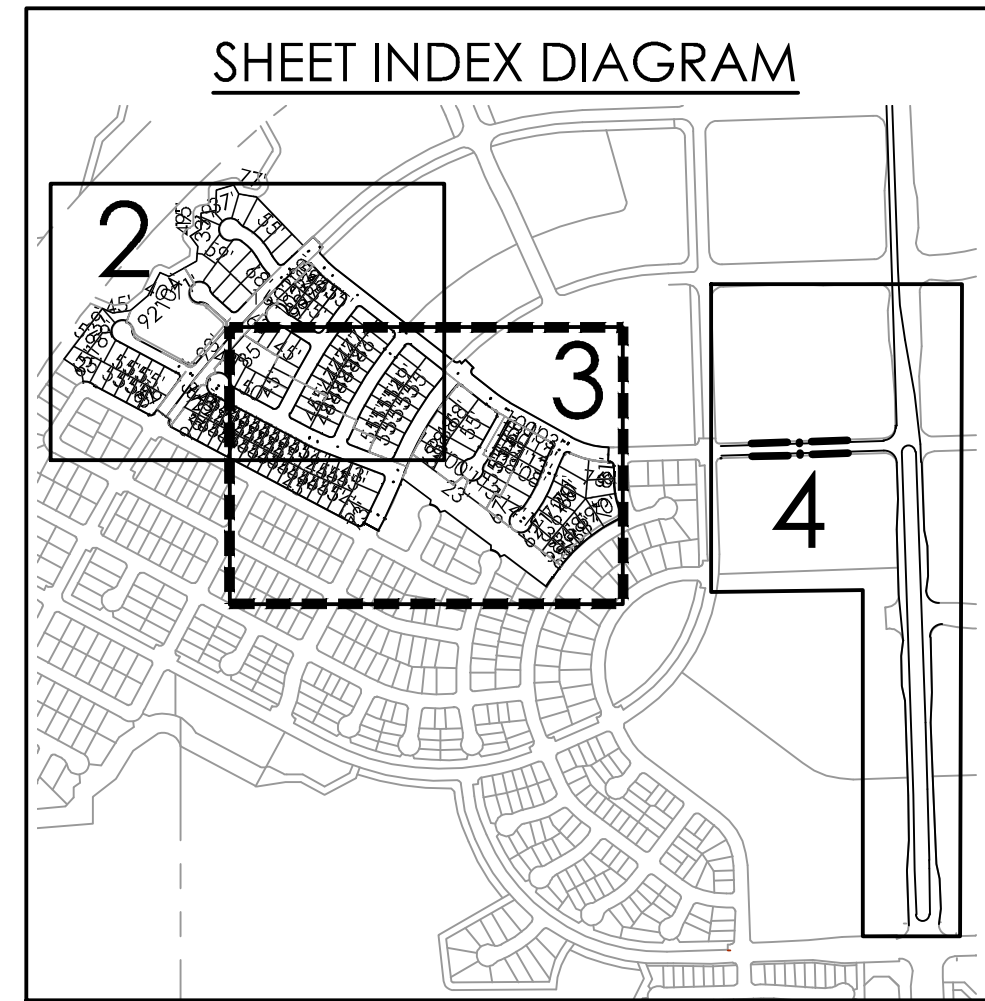

TENTATIVE SUBDIVISION MAP AMORUSO RANCH PHASE 1 - SUBPHASE A2

CITY OF ROSEVILLE, CALIFORNIA
NOVEMBER 1, 2022

LEGEND			
PROJECT BOUNDARY	--- --	SEWER MAIN	—●—
VILLAGE LOT LINE	--- --	SEWER MANHOLE	●
RIGHT-OF-WAY	— — — —	DRAINAGE MAIN	—●—
STREET CENTERLINE	— — — —	DRAINAGE MANHOLE	●
PROPOSED LOTS	— — — —	DRAIN INLET	—■—
		WATER MAIN	—●—
		TOP BACK OF CURB	— — — —
		SIDEWALK	— — — —
		LIP OF CURB	— — — —
		GATE VALVE	—■—
		FIRE HYDRANT	—■—

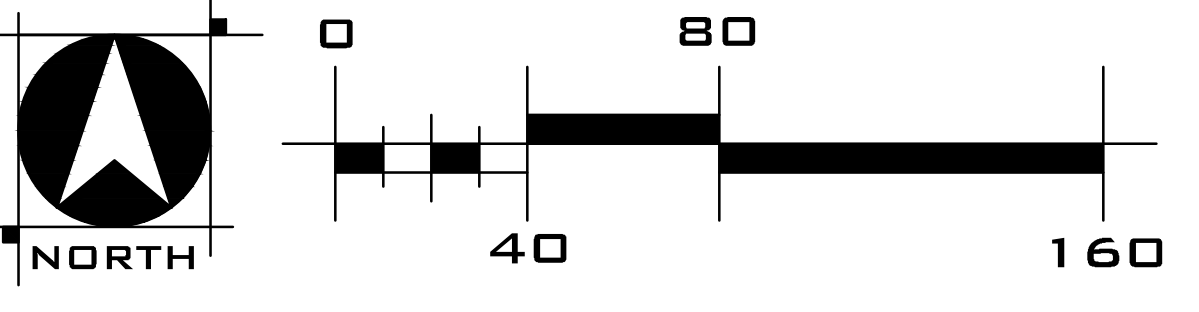

WOOD RODGERS
DEVELOPING INNOVATIVE DESIGN SOLUTIONS
3301 C St, Bldg. 100-B
Sacramento, CA 95816
Tel 916.341.7760
Fax 916.341.7767

CITY APPROVAL STAMP

SHEET 3 OF 4

AMORUSO RANCH PHASE 1 - SUBPHASE A2

CITY OF ROSEVILLE, CALIFORNIA
NOVEMBER 1, 2022

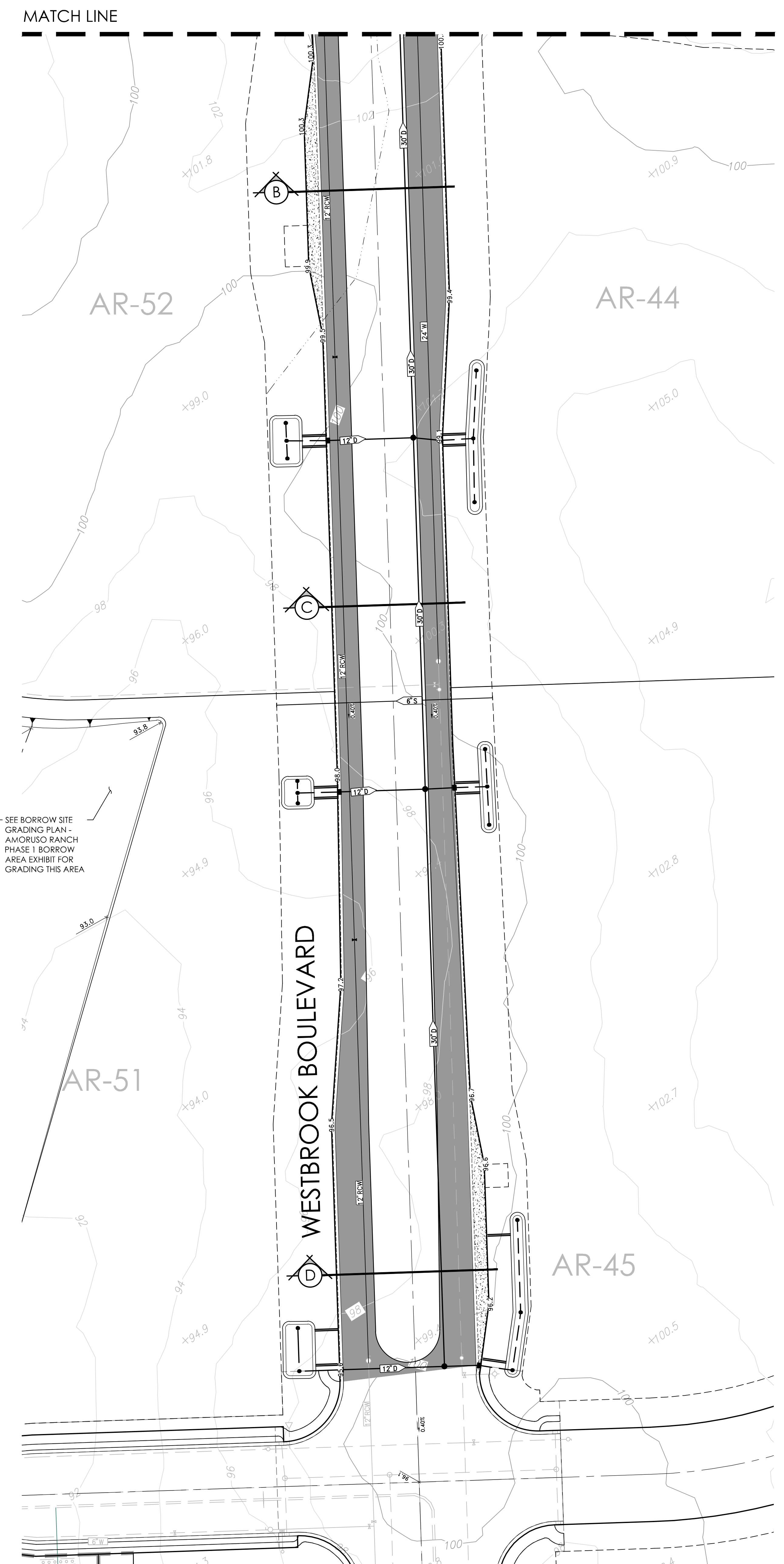
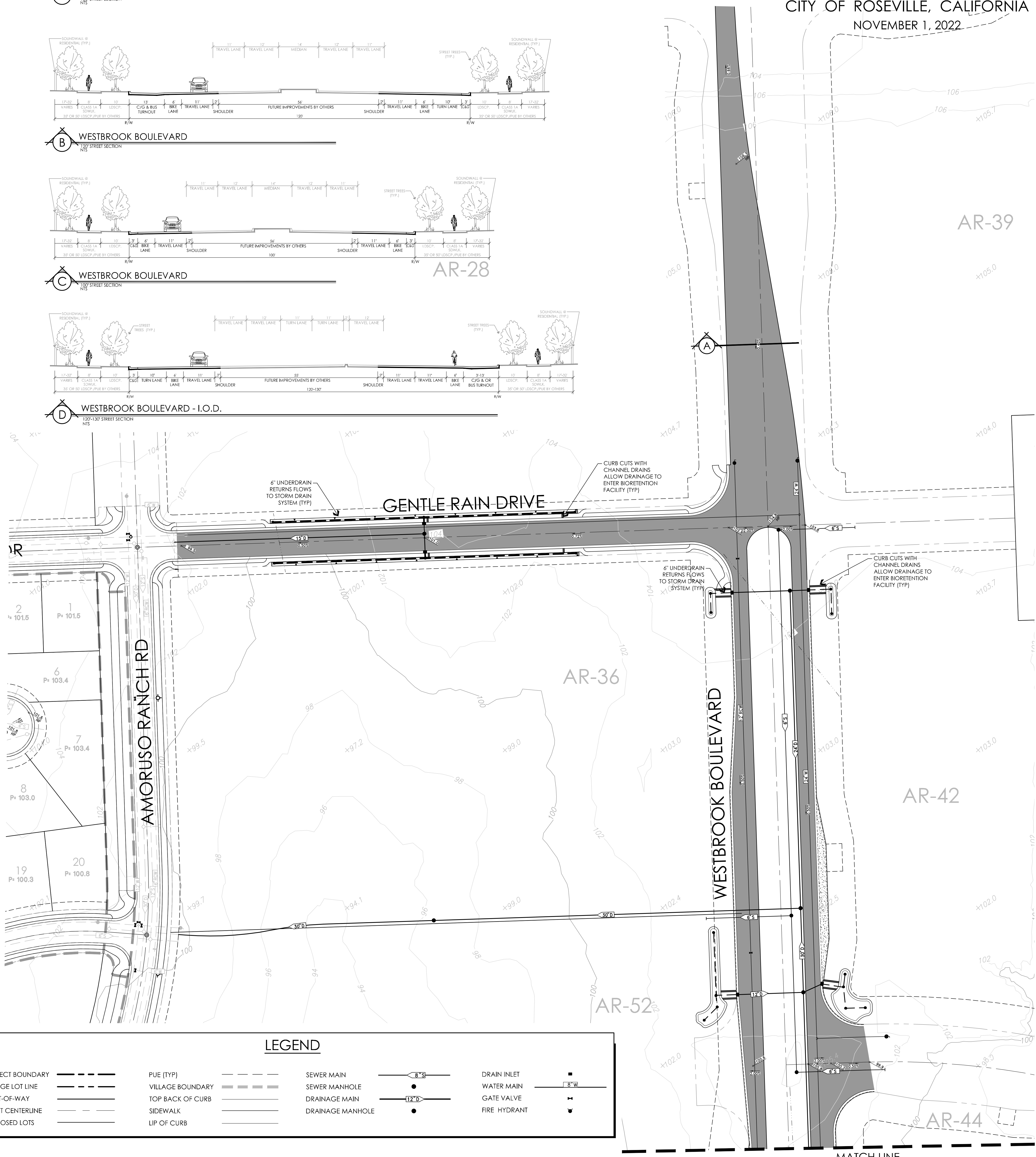
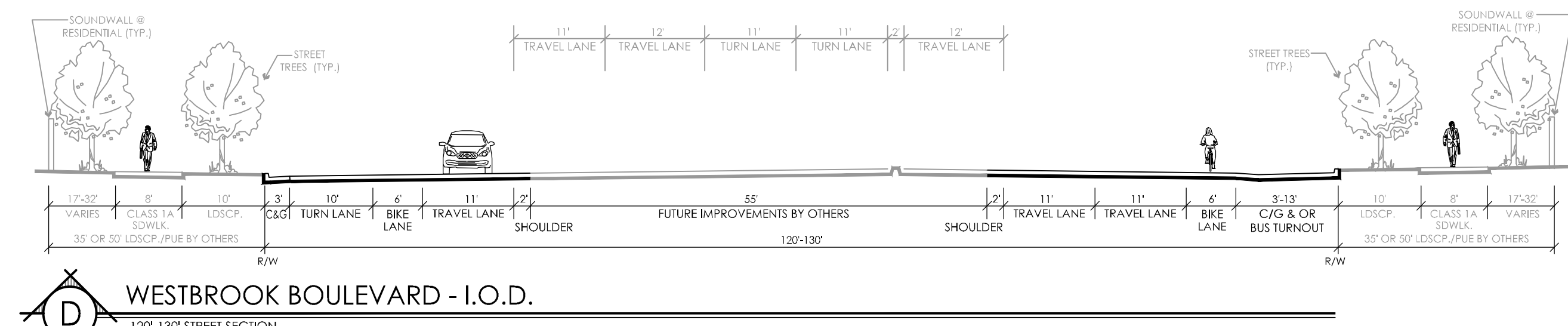
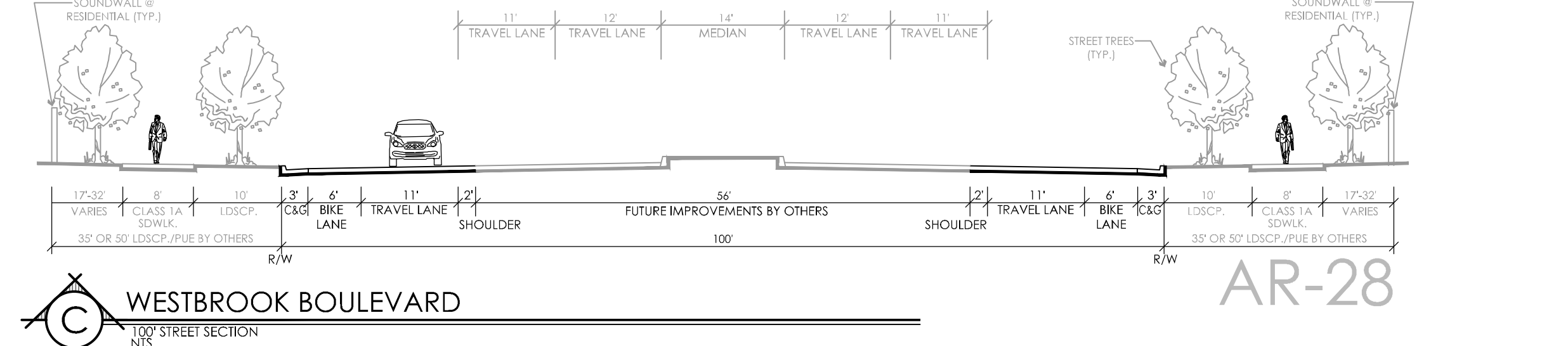
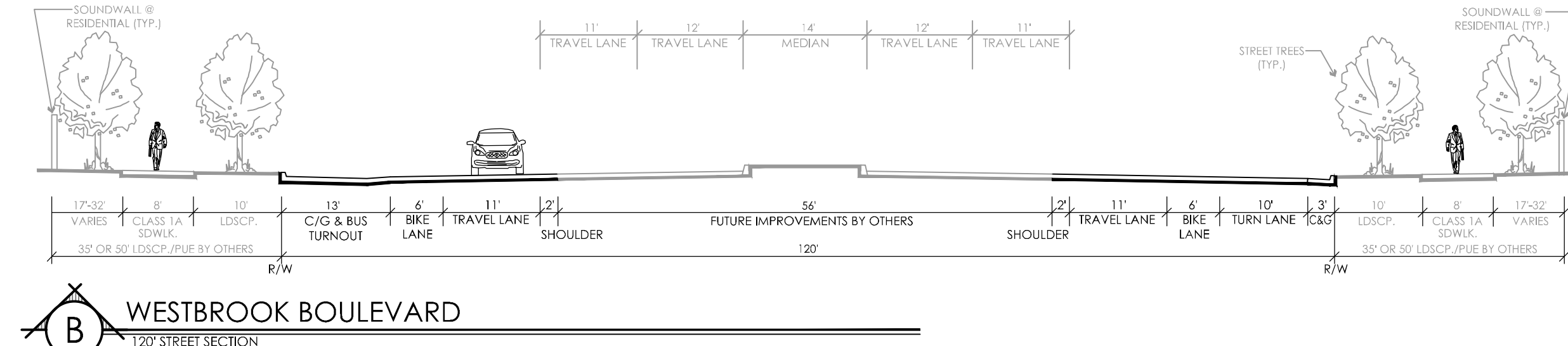
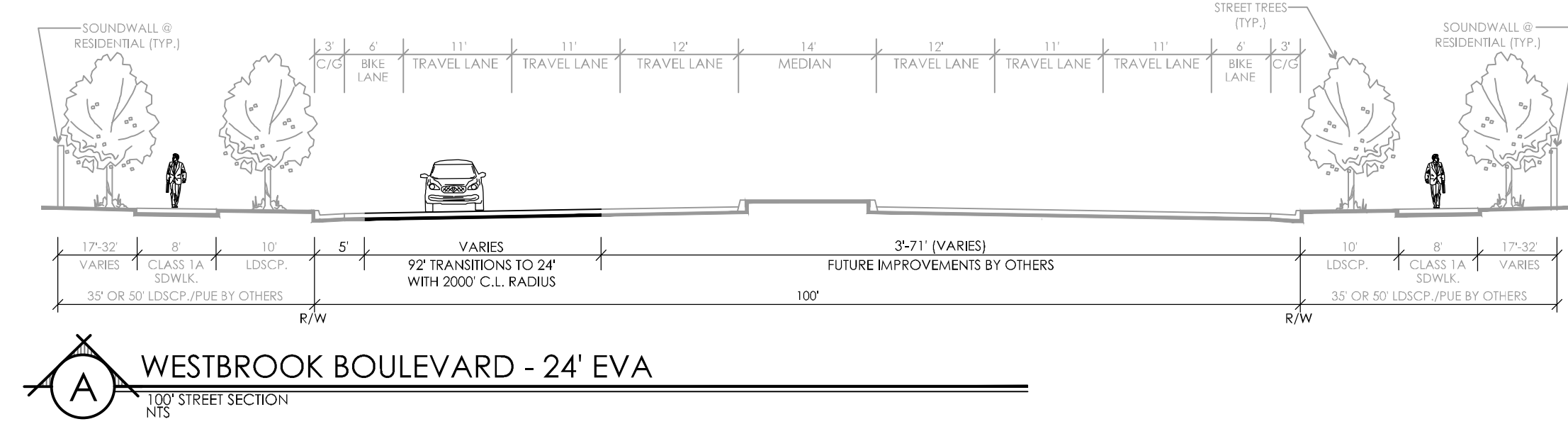
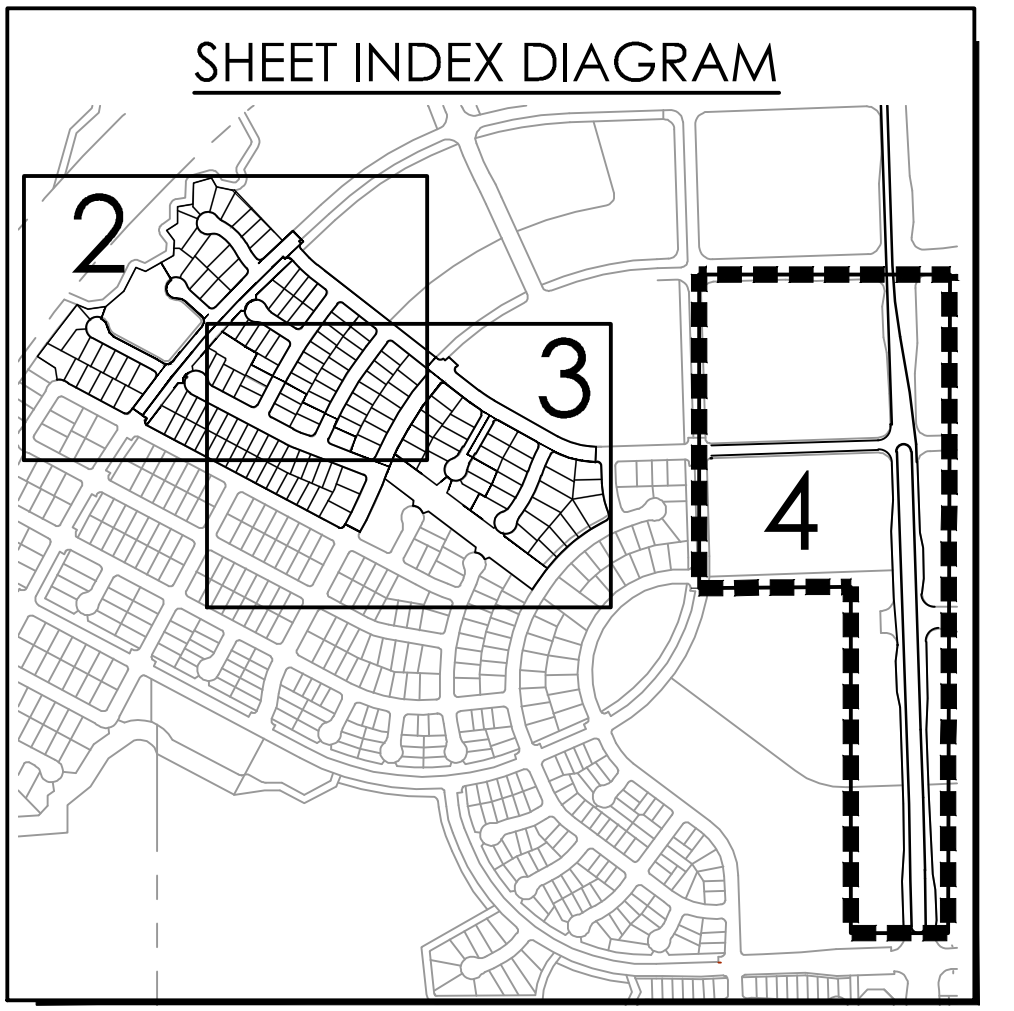

LEGEND

PROJECT BOUNDARY	PUE (TYP)	SEWER MAIN	DRAIN INLET
VILLAGE LOT LINE	VILLAGE BOUNDARY	SEWER MANHOLE	WATER MAIN
RIGHT-OF-WAY	TOP BACK OF CURB	DRAINAGE MAIN	GATE VALVE
STREET CENTERLINE	SIDEWALK	DRAINAGE MANHOLE	FIRE HYDRANT
PROPOSED LOTS	LIP OF CURB		

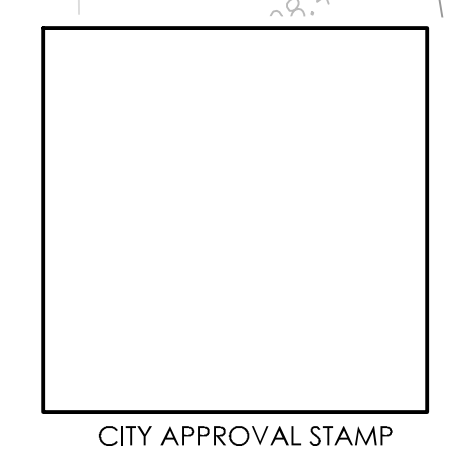
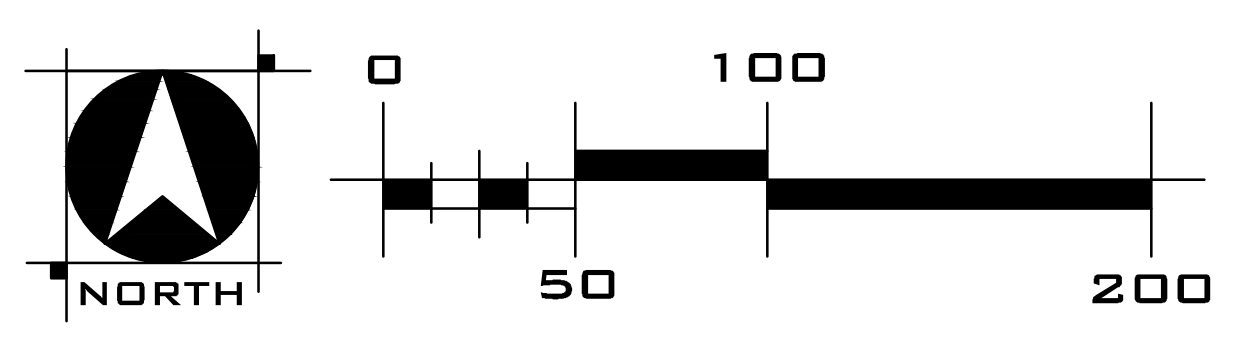

WOOD RODGERS
DEVELOPING INNOVATIVE DESIGN SOLUTIONS
3301 C St. Bldg. 100-B
Sacramento, CA 95816
Tel 916.341.7760
Fax 916.341.7767

BORROW SITE GRADING PLAN

AMORUSO RANCH PHASE 1 BORROW AREA

Exhibit A

BROOKFIELD RESIDENTIAL
ROSEVILLE CALIFORNIA

OCTOBER 26, 2022

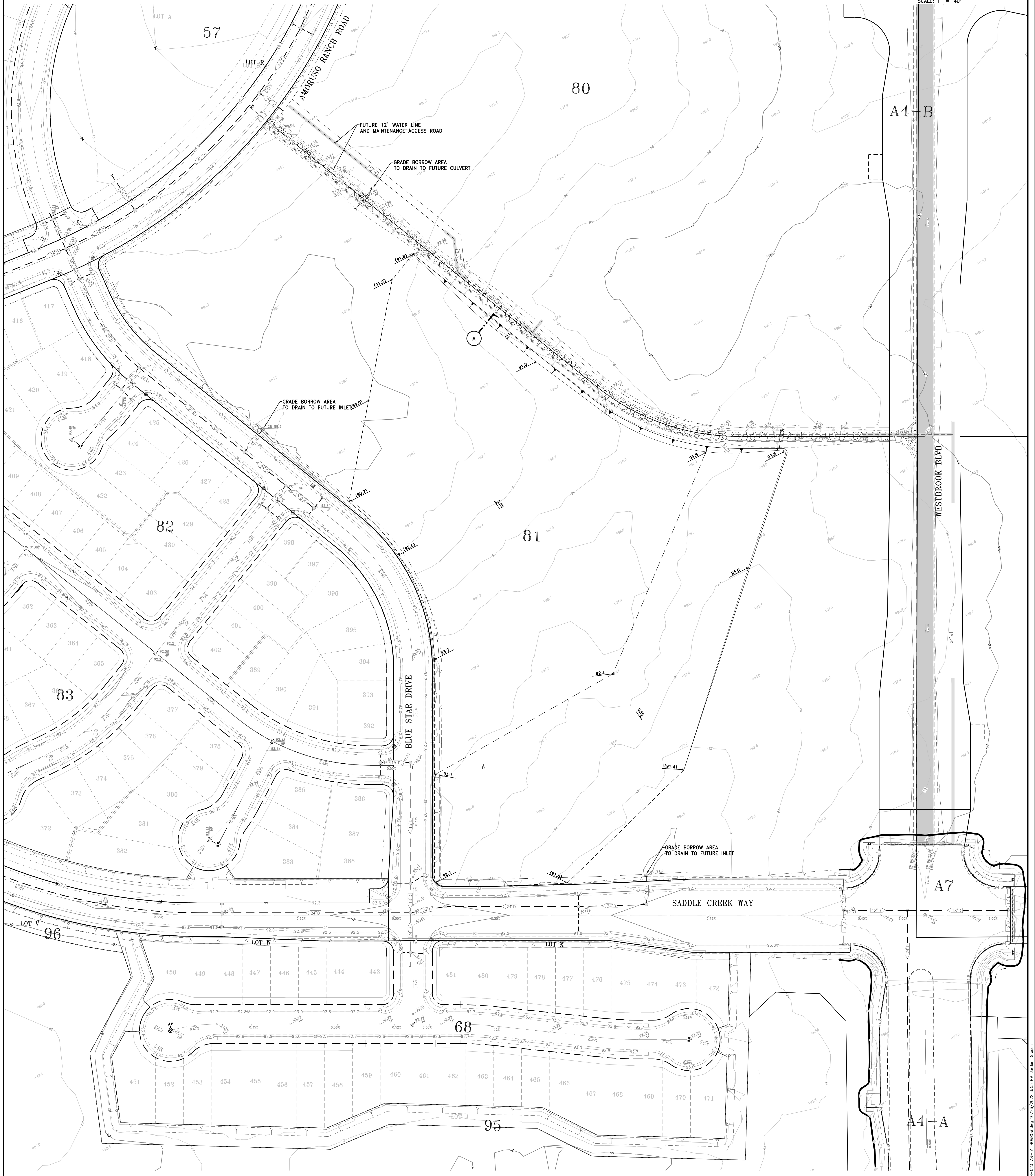
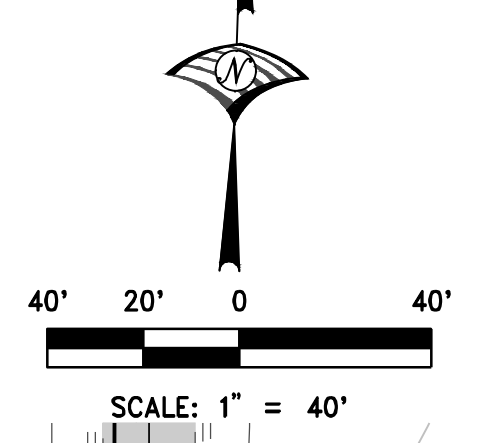

EARTHWORK SUMMARY				
		CUT (CY)	FILL (CY)	NET (CY)
SUBPHASE A2	RAW EARTHWORK	47,900	66,100	
	CUT SHRINKAGE ADJUSTED	39,750	66,100	26,350 IMPORT
LOT 81	RAW EARTHWORK	31,750	-	
	CUT SHRINKAGE ADJUSTED	26,350	-	26,350 EXPORT
TOTAL		66,100	66,100	-

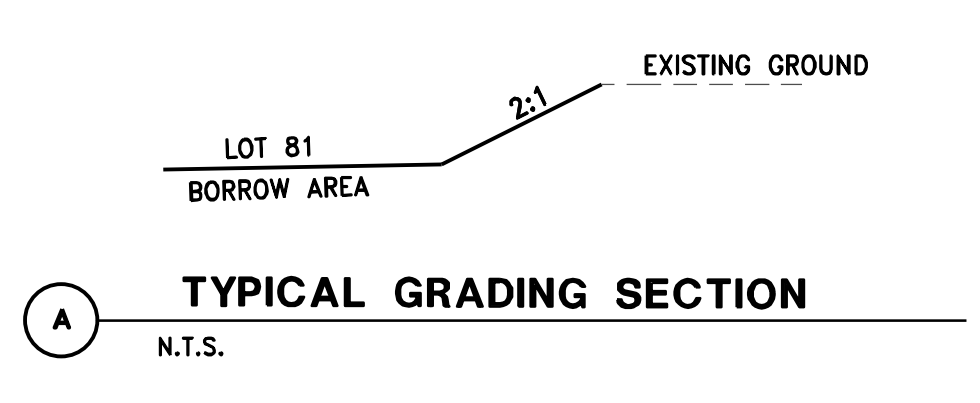

NOTES:
1. CONTRACTOR TO VERIFY QUANTITIES PRIOR TO GRADING OPERATIONS AND INFORM ENGINEER OF ANY DISCREPANCIES.



WOOD ROGERS
BUILDING RELATIONSHIPS ONE PROJECT AT A TIME

3301 C ST, BLDG. 100-B TEL 916.341.7760
SACRAMENTO, CA 95816 FAX 916.341.7767

A:\2022\13851_AmorusoRanch\Drawings\BORROW\DWG\BORROW.dwg 10/26/2022 3:53 PM Jordan Dossier

PHASE 1 SUBPHASE A2 EXISTING AND PROPOSED VILLAGE BOUNDARIES AMORUSO RANCH CITY OF ROSEVILLE, CALIFORNIA

OCTOBER 31, 2022

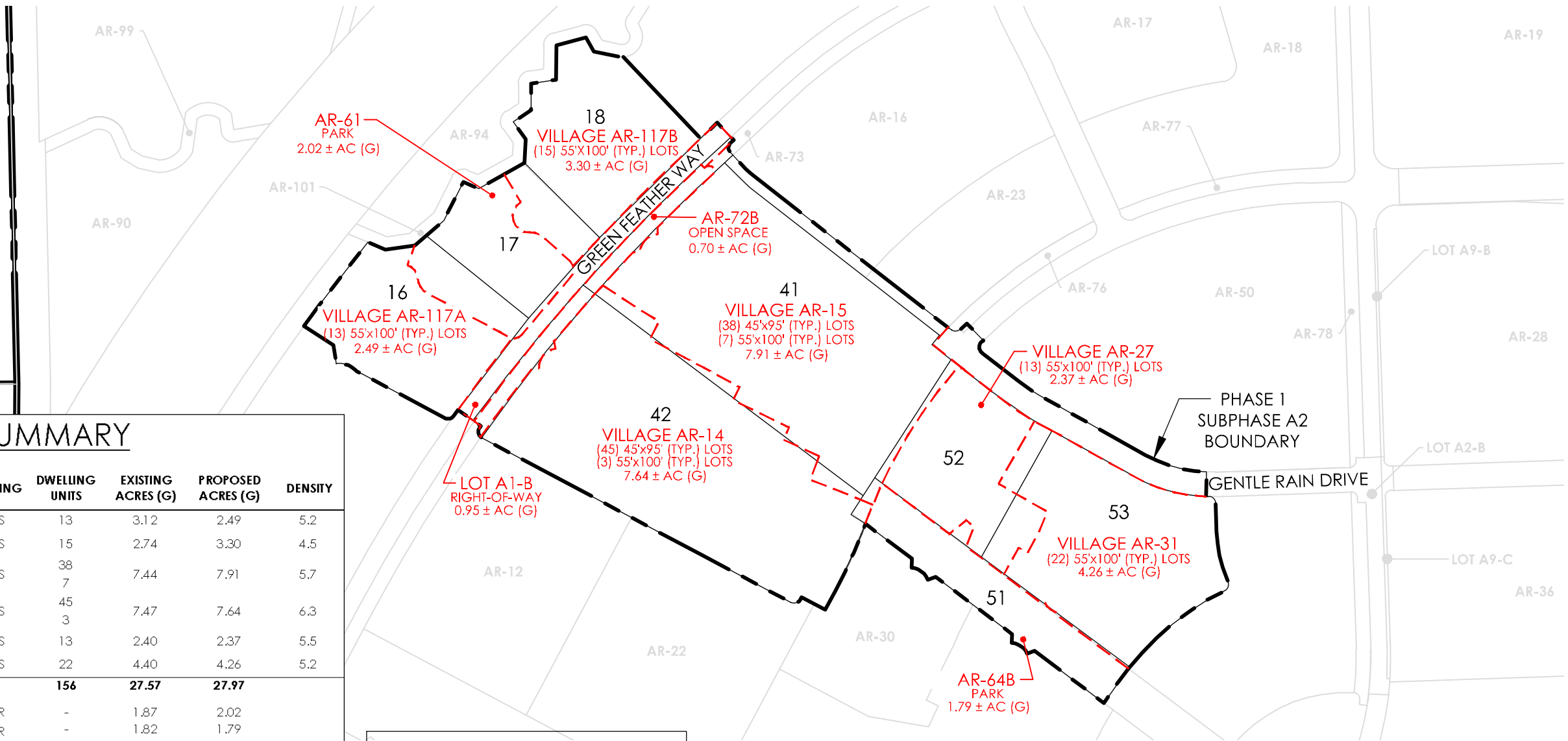

PLACER COUNTY
CITY OF ROSEVILLE

LAND USE SUMMARY

FINAL MAP LOT NO.	SPECIFIC PLAN PCL. NO.	GENERAL PLAN DESIGNATION	SPECIFIC PLAN DESIGNATION	ZONING	DWELLING UNITS	EXISTING ACRES (G)	PROPOSED ACRES (G)	DENSITY
16	AR-117A	LDR	LDR	RS	13	3.12	2.49	5.2
18	AR-117B	LDR	LDR	RS	15	2.74	3.30	4.5
41	AR-15	LDR	LDR	RS	38	7.44	7.91	5.7
42	AR-14	LDR	LDR	RS	45	7.47	7.64	6.3
52	AR-27	LDR	LDR	RS	13	2.40	2.37	5.5
53	AR-31	LDR	LDR	RS	22	4.40	4.26	5.2
SUBTOTAL					156	27.57	27.97	
17	AR-61	P/R	P/R	PR	-	1.87	2.02	
51	AR-64B	P/R	P/R	PR	-	1.82	1.79	
101	AR-72B	OS	OS	OS	-	0.73	0.70	
SUBTOTAL						4.42	4.51	
MAJOR RIGHT-OF-WAY		GENTLE RAIN DRIVE			-	1.48	1.05	
MAJOR RIGHT-OF-WAY		GREEN FEATHER WAY			-	1.01	0.95	
SUBTOTAL						2.49	2.00	
TOTAL					156	34.48	34.48	
					DU	AC	AC	

LEGEND

- EXISTING LARGE LOT PARCEL BOUNDARY
- PROPOSED SPECIFIC PLAN PARCEL BOUNDARY

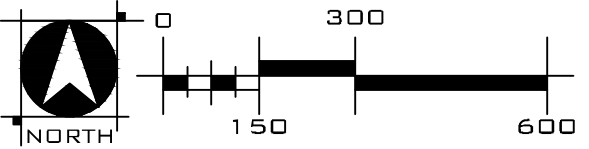

I:\2002\3451_AmorusoRanch\AmorusoRanch-CAD\Planning\AmorusoRanch-CA\Planning\AmorusoRanch-CA\Map\Map_10312022_T1SP_A11 Andrew Marchin